

SEZ.A-A

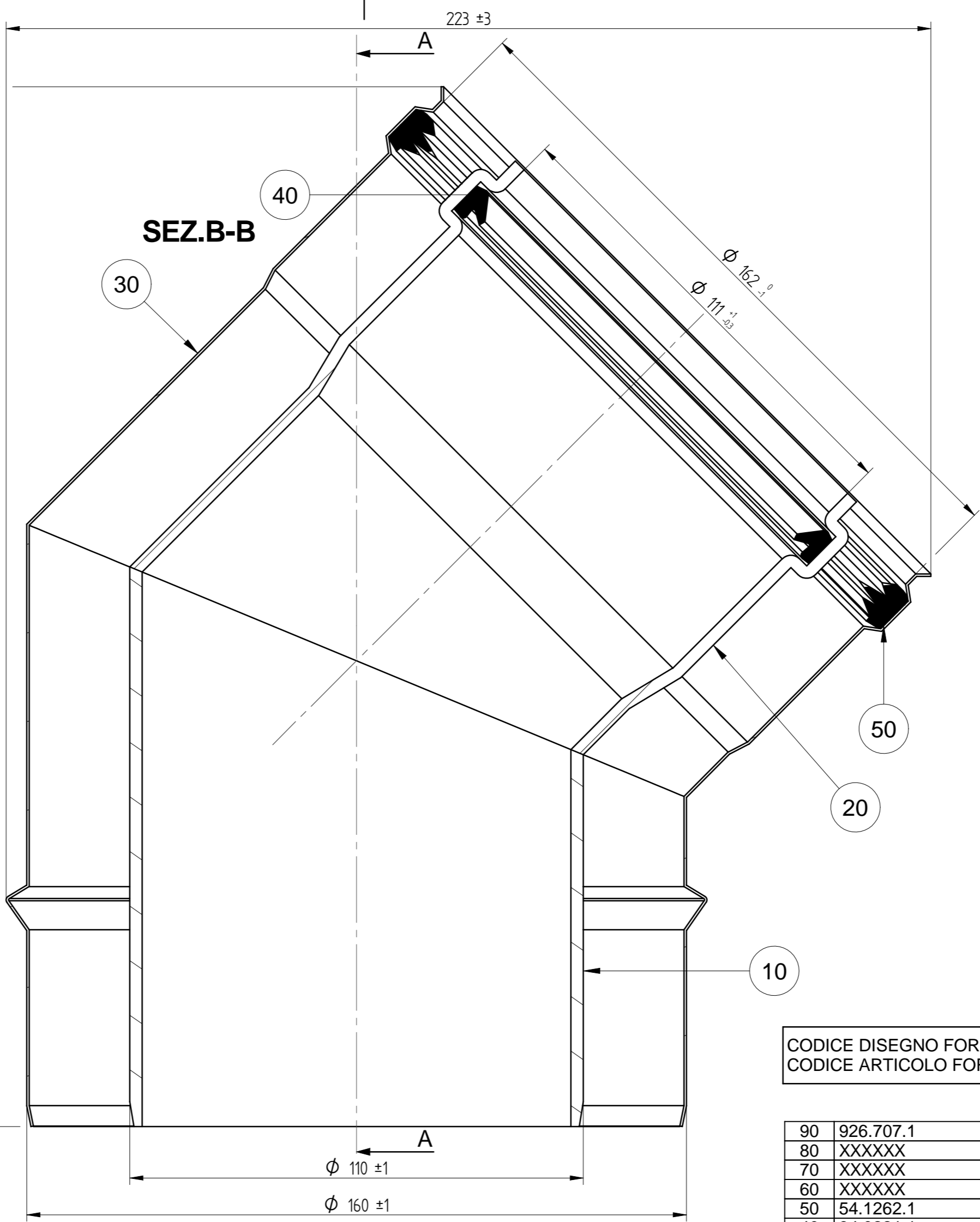

SEZ.B-B

CODICE DISEGNO FORNITORE : 63232853  
 CODICE ARTICOLO FORNITORE: 939584020

ITEM NO	PART NUMBER	DESCRIPTION	QTY
90	926.707.1	ETICHETTA IDENTIFICAZIONE KIT KUG714133510	2
80	XXXXXX	SCATOLA IMBALLO KIT 270x175x200	1
70	XXXXXX	VITE AUTOFILETTANTE 3,5X13 TC Cr ACCIAIO INOX C1 50	2
60	XXXXXX	STAFFETTA IN PP PER CENTRAGGIO INT/ESTØ 110/160	2
50	54.1262.1	GUARNIZIONE Ø 160 MM EPDM OMOLOGATO	1
40	34.0221.1	GUARNIZIONE Ø 110 MM EPDM OMOLOGATO	1
30	XXXXXX	CURVA 45°Ø 160 M-F COLORE BIANCO RAL 9003	1
20	XXXXXX	TUBO Ø 110 M-F PER CURVA 45°M-F COND.	1
10	XXXXXX	TUBO Ø 110 M-M + INVITO PER CURVA 45°M-F COND.	1

CODICE PRODOTTO FINITO CONFEZIONATO BAXI: KUG714133510

ETICHETTA INDICATIVA A CURA DEL FORNITORE  
 DISEGNO NON IN SCALA

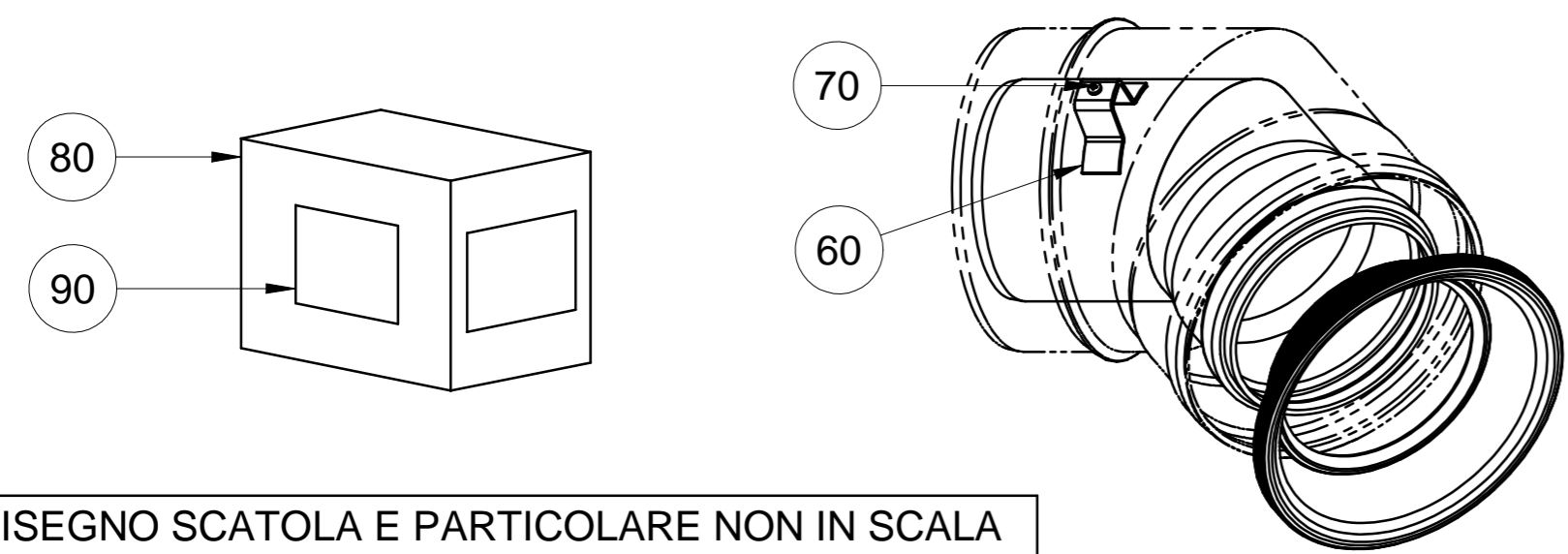

DISEGNO SCATOLA E PARTICOLARE NON IN SCALA

**KUG714133510**

- 45°Ø 110/160 mm BEND
- BOGEN 45°Ø 110/160 mm
- COUDE A 45°Ø 110/160 mm
- CODO DE 45°Ø 110/160 mm
- CURVA DE 45°Ø 110/160 mm
- BOCHT 45°Ø 110/160 mm
- CURVA 45°Ø 110/160 mm

codice a barre tipo C39 vedi KUG71.....  
 \*KUG714133510\*

926.707.1

REVISION	MODIFICATION	ENGINEER	REFERS TO	DATE

<b>BAXI S.p.A.</b> A MEMBER OF BAXI GROUP		RELEASE STATUS: <b>Production</b>	ITEM NUMBER: <b>570466</b>	REVISION: <b>01</b>
		ENGINEER: DALLA COSTA MAURO	DATE: 09-Dec-09	SHEET No. 1 of 1

© 2009	TITLE: CURVA 45 GR. D.110-160 MM M-F
UNITS: mm	SCALE: 1:1
MATERIAL SPECIFICATION: Errore: Nessun riferimento	

FIRST ANGLE PROJECTION.	TOLERANCE TO EN 22768 - mK UNLESS OTHERWISE SPECIFIED	QUALITY SIGNIFICANCE: [C]=CRITICAL [I]=IMPORTANT
		ITEM CATEGORY (1, 2 OR 3) <b>3</b>